

(revised, 3/10/05)

PULSED NUCLEAR MAGNETIC RESONANCE

Advanced Laboratory, Physics 407
University of Wisconsin
Madison, Wisconsin 53706

Abstract

A pulsed nuclear magnetic resonance technique is used to determine the T_1 and T_2 relaxation times of proton magnetic moments in several liquid samples. Unlike the continuous radiofrequency field experiment, this experiment uses a pulsed radiofrequency which rotates the proton spins through 90° and 180° . Signals are detected immediately after the pulsed excitation stops. The observable effects are comparable to the free vibration or ringing of a resonant cavity on an atomic scale. The techniques used here are the basis of Magnetic-Resonance Imaging in the medical field today.

A Conceptual Tour of TeachSpin's Pulsed NMR

Pulsed nuclear magnetic resonance begins with the net magnetization of the protons of a sample in thermal-equilibrium in a strong magnetic field which is designated B_0 . There is a net alignment of the spins with this field which is considered to be directed along the +z axis. In the TeachSpin PNMR, this is the field of the **permanent magnet**. The direction of the net magnetization is altered by one or more 90° or 180° rf pulses. The spins, tipped into the x-y plane, then precess around B_0 creating a time varying voltage in a pick-up coil. The **pickup coil** monitors only magnetization in the x-y plane.

Figure 1 shows an artist sketch of the sample probe. The transmitter coil is wound in a Helmholtz configuration with its axis perpendicular to the constant magnetic field, B_0 , of the permanent magnet. The transmitter applies the oscillator's rf pulse to the sample "tipping" the spins. The receiver pickup coil is tightly wound in a solenoid configuration around the thin walled tube which holds the sample vial. The pickup coil's axis is perpendicular to both the axis of the transmitter coil and the magnetic field of the permanent magnet. The pickup coil "senses" the precession of the magnetization in the field of the permanent magnet.

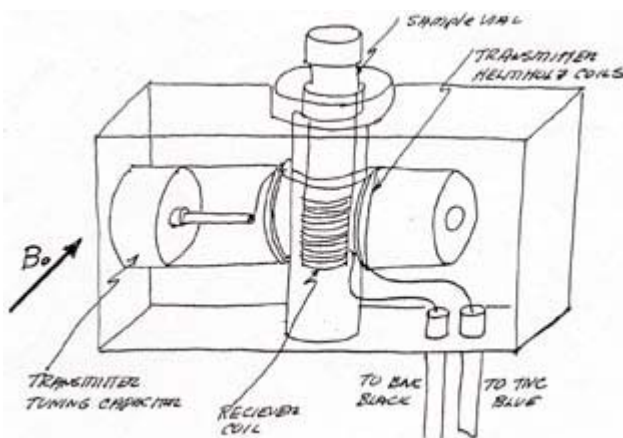

Figure 1 – Artist Sketch of Sample Probe

The precessing magnetization induces an emf in the pickup coil which is subsequently amplified by the circuitry in the receiver. The coaxial cables for both the transmitter and receiver coils are permanently mounted in the sample probe.

Figure 2 is a schematic showing a view of the system looking down into the magnet. In this view, the central circle represents the sample. The B_0 arrows represent the magnetic field of the permanent magnet. The double ended arrow B_1 , represents the rf field used to tip the spins.

Initially, the net magnetization of the sample is aligned along B_0 , the field of the permanent magnet. The rf coils produce a field, B_1 , which can be visualized as the sum of two counter rotating fields. If the rf pulse is at the Larmor frequency, the spins will precess around the direction of the B_1 field. The duration of the pulse is adjusted to give a 90° spin flip orienting the net magnetization of the sample perpendicular to the page. After the B_1 pulse, the spins will precess around the B_0 field.

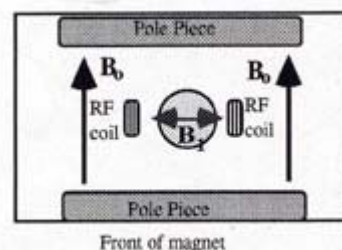

Figure 2 – Top View of Magnet

There are **two different GAIN mechanisms**.

1. The **Gain** on the PNMR receiver module amplifies the signal coming from the pick up coil. The ability of the PNMR to magnify in this way does have limits. The oscilloscope will show a flat top on the signal if you have reached the maximum output signal.
2. The gain on the oscilloscope is basically an enlarger which just makes the “picture” of the signal on the scope larger. It also amplifies the noise.

Pulse width is a time measure. When starting from equilibrium, a 90° pulse tips the spins until they are perpendicular to the strong, constant, magnetic field of the permanent magnet, B_0 . For a 90° pulse, the pulse width is the time it takes the rf magnetic field to tip the spin 90° . (In the Magnetic Torque apparatus, this “pulse” time is equivalent to how long you must rotate the horizontal field to get the ball’s handle, and thus its magnetic moment, horizontal.)

A single isolated proton (or a Magnetic Torque snooker ball with **no** frictional effects) would maintain its tipped magnetization indefinitely. In reality, the spins do realign to the primary field and a characteristic of the time this takes is known as the **spin-lattice relaxation time, T_1** .

REPETITION TIME tells how often the entire pulse sequence is repeated. This time must be long enough for the net magnetization to realign with the primary field after the pulses are over. If it is too short, a pulse sequence will begin when the system is not in thermal equilibrium.

DELAY TIME, τ , is the time between the first and second pulses of a series. When more than two pulses are used, the system adjusts subsequent delay times between the second and third, third and fourth etc. to 2τ . The total time for an entire pulse series must be less than the repetition time so that the digital logic does not lock up. **Repetition time should be such that the time after the last echo or FID is long compared to T_1 . To be safe it should be close to $10T_1$.**

Describing Relaxation Time

The PNMR responds to the sum of the magnetic moments of many protons, the net magnetization. (This is different from the Magnetic Torque Apparatus. Magnetic Torque works with the spin of only one “proton” which is represented by the ball.) The net magnetization of the protons of the sample becomes aligned with the field of the permanent magnet, B_0 . Any change in the orientation of the spins decays back to an alignment with the “primary” field. The time characteristic of this return to thermal equilibrium magnetization is called a relaxation time. The TeachSpin PNMR can be used to measure two different quantities referred to as T_1 and T_2 . T_1 , the spin-lattice relaxation time is the time characteristic of establishing thermal-equilibrium magnetization in the z direction. T_2 , spin-spin relaxation time, is the time characteristic of the loss of x-y magnetization. In PNMR, the x-y magnetization is created by tipping the spins 90° from their thermal equilibrium condition.

Getting Started – An Exploratory Experiment

Begin by investigating the PNMR signal following a single pulse. Start with all pulse width dials in the counter clockwise position, the repetition time set to about 0.10 seconds, the A pulse on, the B pulse off and the oscilloscope triggering on A.

Slowly increase the A pulse width and examine the effect. (To be sure the rf pulse is in resonance, check the mixer signal on the oscilloscope and tune it until there is zero beat condition.) Pulse width determines the time allowed for the rf to tip the spins. The longer the rf is on, the farther the spins tip. You will notice that the initial height of the FID (the signal on the oscilloscope), first reaches a maximum, indicating a 90° pulse, then decreases to close to 0 at

about twice the 90° pulse width, indicating a 180° rotation. After a 180° rotation there is no x-y magnetization. Continuing to increase the pulse width shows the signal increase to another maximum for a 270° rotation etc.

The repetition time can be used to get a rough estimate of T_1 , the time to re-establish the thermal equilibrium. Set the A pulse width at the first maximum. Decrease the repetition time until the signal maximum begins to shrink. This decrease in the initial height of the FID occurs because the z-magnetization has not returned to its thermal equilibrium value before the next 90° pulse. This effect becomes more dramatic as the repetition time decreases. To make sure the PNMR is giving accurate information, the repetition time for any pulse sequence should be set so that the time between the last pulse in the sequence and the beginning of the next sequence is at least 10 T_1 .

Determining T_1 , the spin-lattice relaxation time

(The time characteristic of establishing thermal equilibrium magnetization in the z direction)

To measure T_1 , the net magnetization, M_0 , is first tipped by 180° to $-M_0$. The z-magnetization is then interrogated as it returns to its thermal equilibrium value, M_0 . Because the pickup coil only indicates precession in the x-y plane, this magnetization along the z-axis cannot be monitored directly. Therefore, the B pulse is adjusted to create a 90° pulse and the oscilloscope is triggered on the B pulse.

To tip the magnetization to $-M_0$, the width of the A pulse is increased until it has passed through the first maximum and returns to a 0 signal on the oscilloscope. This indicates a 180° pulse after which there is no net magnetization in the x-y plane. The width of the B pulse is adjusted to the first maximum signal, indicating a 90° pulse.

The key to this experiment is the fact that the B pulse, which tips *any* spin by 90°, is being used to interrogate what has happened to the magnetization along the z axis. The maximum amplitude of the Free Induction decay (FID) signal which follows the B pulse is directly proportional to the magnitude of M_z at the time the B pulse occurs. For example, if the delay time for B, following A, were to be 0, the signal would be at a maximum because the spins would be tipped from -z to the x-y plane.

By changing the delay time between the A and B pulses, the rate at which the net magnetization returns to alignment with the “primary” magnetic field can be investigated. When the delay time results in a 0 signal in the pick up coil, it means that the net magnetization along the z-axis is zero. When the signal again reaches a maximum, the spins have “relaxed” back to alignment along the z-axis. Careful observation of the mixer signal will show a phase shift as the magnetization passes through 0.

If the maximum amplitude, M , of the FID following the 90° pulse is plotted against the delay time, the relaxation of the spins from -z to +z can be observed. To extract T_1 correctly, however, the difference between the FID maximum for long delay times, which is a measure of the thermal equilibrium magnetization, and the FID maxima at time t is plotted against delay time. It is this difference, $M_0 - M$, which changes exponentially. The equation is:

$$\frac{dM_z}{dt} = \frac{M(t) - M_0}{T_1}$$

An arbitrary scale can be used to plot the magnitude of the initial FID signal after the B pulse as a function of delay time. From the shape of this curve, T_1 can be calculated.

Figure 5 shows diagrams of both the actual net magnetization M and the maximum amplitude of the FID just after the 90° pulse as a function of time.

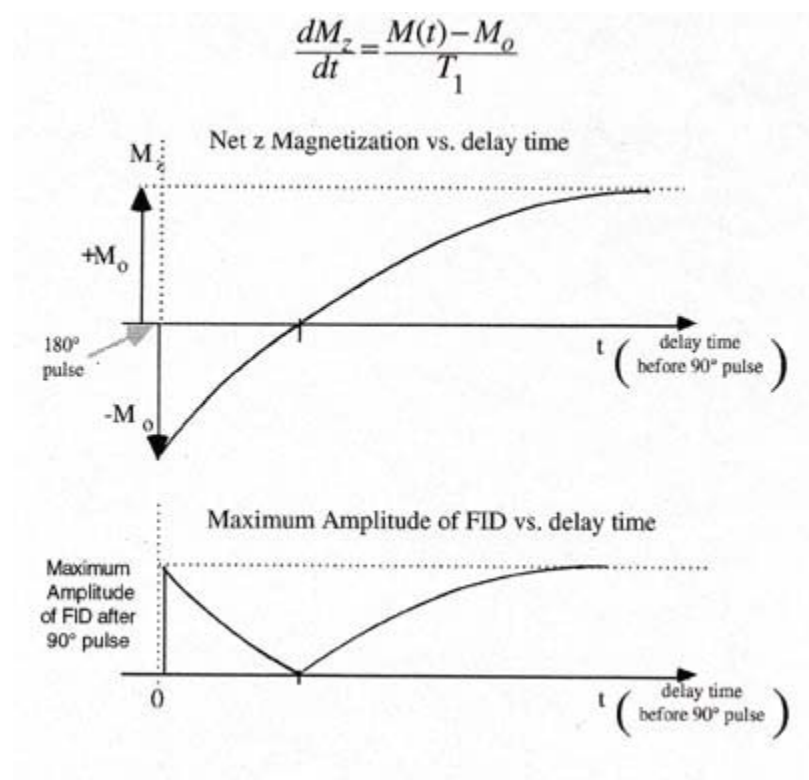

Figure 5 – Upper Diagram: Net z magnetization vs. delay time
 Lower Diagram: Maximum Amplitude of FID vs. delay time

Measuring T_2 , the spin-spin relaxation time (The time characteristic of the loss of x-y magnetization)

The characteristic time for the spins to lose a non-thermal equilibrium x-y magnetization, which has been established by a 90° rf pulse, is called T_2 . To measure this relaxation time, the width of the A pulse is adjusted to the first maximum signal, indicating a 90° pulse. The oscilloscope must trigger on A.

In the pick-up coil, the precessing spins induce a sinusoidally varying voltage which decays over time. As discussed at the beginning, the detector transmits only the absolute value of the maximum voltages during each precession. The rectified envelope represents the free induction decay or FID

Spin-spin relaxation occurs by two mechanisms:

1. The spins re-orient along the + z axis of the main magnetic field, B_0 due to stochastic, T_1 , processes.

- The interaction of the spins themselves creates a variation in the local magnetic field of individual atoms. Because their precession frequency is proportional to the magnitude of the local magnetic field, the precessing spins dephase.

Understanding T₂*

If the external magnetic field across the sample is not perfectly homogenous, spins in different physical locations will precess at different rates. This means that the precession of the individual spins is no longer in phase. Over time, the phase difference between the precessions of the individual protons increases and the net voltage induced in the pick-up coil decreases. The time for this loss of signal, which is not due to relaxation processes, is called T₂*. The free induction decay observed after a single 90° pulse is often due primarily to this effect. If, however, the external magnetic field is very homogeneous and T₂* is long compared to T₂, the free induction will represent a true measure of T₂.

Spin Echo

In 1950, Irwin Hahn found a way to compensate for the apparent decay in the x-y magnetization due to inhomogeneity of an external magnetic field. The external inhomogeneity creates a variation in the proton precession times around an average. The introduction of a 180° pulse, or spin flip, allows the spins to regroup before again dephasing. This creates a *spin echo* which allows us to measure the true T₂.

After the 180° flip, spins that were “ahead” because they are in a stronger field are now “behind.” Because their protons are precessing faster, however, they will now “catch up” to the “average.” In the same way, after the 180° pulse, “slow” spins are now “ahead” and the “average” will overtake them. The spins rephase momentarily and dephase again. This is why the oscilloscope trace after the first 180° pulse shows a rise to a maximum and then a decay. The rephasing and dephasing wings of the echo can be seen in the diagram below. The difference between the height of the initial signal and the echo maximum is due to the actual stochastic processes of T₂.

The magnitude T₂ can be investigated two ways. The time between the A and B pulses can be varied and T₂ determined by plotting the resulting echo maximum as a function of time. Another option is to introduce a series of 180° B pulses and look at the decrease of the maxima.

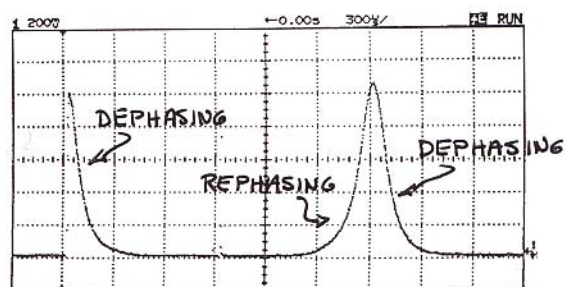

Figure 6 – Oscilloscope Trace Showing Spin Echoes

Understanding the effect of the 180° Spin Flip - a Jonathan Reichert analogy

Consider the plight of a kindergarten teacher who must devise a foot race which keeps all children happy, no matter how fast they run. What if the race has the following rules? All children are to line up at the starting line. At the first whistle they are to run as fast as they can down the field. At the second whistle they are to turn around and run back toward the starting line. First person back wins!! Of course, it is a tie, except for the ones who “interfere” with one another or fall down. As the children run away the field spreads out with the fastest ones getting

farther and farther ahead. At some point there is no semblance of order. On the trip back, as the faster ones overtake the slow guys now in the lead, the group comes together again “rephasing” as they pass the start line.

This is a good analogy for the effect of the 180° spin flip which creates a spin echo. The effect of the 180° pulse is analogous to that of the kindergarten whistle. After the 180° pulse, the signal increases as the spins rephase, hitting a maximum somewhat lower than the initial height of the FID and decreasing as the spins again dephase. The decay of the maxima shows how the protons are losing the x-y magnetization. In our kindergarten analogy, this tells us the rate at which the children are actually interacting with each other.

The Output of the Mixer as a Phase Indicator

During a T_1 measurement the output of the mixer can be used to determine when the direction of the magnetization changes from the minus to the plus z direction. This cannot be inferred from detector output because it always gives a positive signal on the oscilloscope. By watching the mixer as delay time is changed you can see when the magnetization passes through the x-y plane. The initial signal of the mixer can have its maximum either above or below the time axis on the oscilloscope when the net magnetization of the sample has been driven to $-M_0$ by the A pulse. As the direction of the net magnetization changes from below ($-z$) to above ($+z$) the x-y plane, the mixer signal will reverse its orientation around the time axis of the oscilloscope. If you have truly caught the moment when the net magnetization is in the x-y plane, both the pick up signal and the mixer signal will be 0. The way this time can be used to give a very good estimate of T_1 is discussed in the PNMR manual.

An Interesting Activity

With the pulse series for determining T_2 on the oscilloscope screen (a MG pulse sequence), move the sample to a less homogeneous region of the magnet. Notice that although the widths of the individual echo traces narrow, the maximum heights of the peaks do not change. This shows that although the time for the spins to dephase due to inhomogeneity does decrease, the true time for the spins to return to their thermal equilibrium value, as indicated by the decay of the peaks, does not.

Pulsed NMR

1/31/05

Pulsed NMR is widely used for chemical analysis, in Magnetic Resonance Imaging (MRI), and in a number of other applications of magnetic resonance. In this lab, you will set up a pulsed NMR experiment and measure the time constants T_1 and T_2^* . These measurements are made with protons in various samples with ω_0 near 15 MHz, and $B_0 \approx 0.35$ T. A separate section of this Lab Manual provides a necessary introduction to NMR and many of the phenomena and terms discussed here.

The Apparatus

The apparatus is illustrated in Fig. 1. The B_0 field is provided by a permanent magnet consisting of two parallel pole tips connected by a soft-iron flux return. The pole tip separation can be adjusted to affect the uniformity of \vec{B}_0 . The NMR probe consists of a pair of coils oriented with perpendicular axes with both perpendicular to \vec{B}_0 . One coil, the transmitter coil, produces the oscillating field \vec{B}_1 . The transmitter coil is connected to the output of an RF amplifier that provides the RF current with the input from a programmed synthesizer. The second coil is a pick-up coil that is connected to a low noise RF preamplifier. (RF means radio frequency, and corresponds to a broad range of from 100 kHz to about 100 MHz)

The B_1 field is applied in pulses of variable duration. This is achieved with an electronic switch that is controlled by logic signals from the pulse programmer. The pulses are “top hat” shaped and can be varied in duration, number of pulses and repetition time. For example, the spin echo sequence requires an initial $\pi/2$ pulse followed by a π pulse at some later time. Special pulse sequences used to separate T_2 from T_2^* require an initial $\pi/2$ pulse followed by a series of π pulses.

In most applications where high frequency signals are measured, we do not directly monitor at RF frequencies, rather we use a form of detector that generates a low frequency beat by mixing the signal with a reference or carrier signal of nearly the same frequency. In the pulsed NMR apparatus, a single tunable signal generator is used to generate $\vec{B}_1(t)$ and the reference signal. Alternatively, the RF signal can be rectified and converted to a measure of the signal amplitude. The PS1-A apparatus has both a mixer that produces a low frequency beat signal and an RF detector that produces a DC signal proportional to signal amplitude.

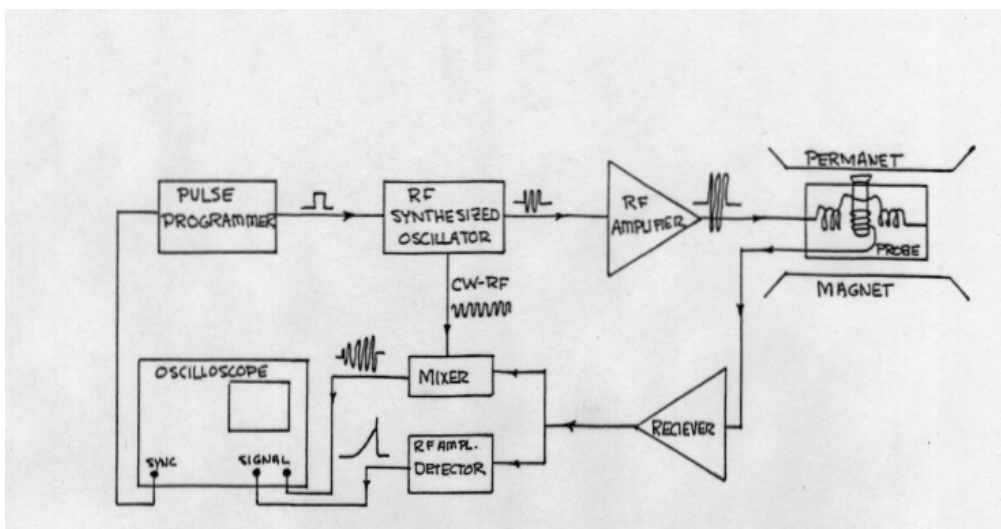

Figure 1. A schematic diagram of the major components of the pulsed NMR experimental apparatus.

To gain familiarity with the apparatus, use an oscilloscope to understand each of the following functions: pulse sequencing, detection, the signal mixing to low frequency and RF amplitude detection.

First observe the CW-RF generator output. You should measure a sinusoidal signal of frequency about 15 MHz. Note that coarse and fine tuning do not discernibly change this frequency.

This is because the frequency changes are much smaller than 15 MHz. In order to detect such small changes of frequency, we would use the mixer technique to derive a beat frequency.

Next, hook up the scope to the pulse programmer output. The pulse programmer can produce an initial excitation pulse (A) and one or more subsequent pulses (B) with variable repetition rate. The pulse widths of A and B can be set independently. Set $N = 1$ and observe the programming pulse as you select pulse A, pulse B, or both. Vary the pulse widths and repetition time. Next set N to some number greater than 2 and observe what happens when you vary the repetition time and pulse parameters. The pulse programmer output (A+B OUT) will be connected to the oscillator (A+B IN) to modulate the RF output i.e. the ≈ 15 MHz sinusoid is multiplied by the pulse programmer output. (When the programmer output is LOW (0 V), the RF output is ZERO. The SYNC signal will be used to trigger the oscilloscope. This SYNC can be triggered from A or B. BLANKING is a logic signal used to turn off the preamplifier input during the pulse in order to prevent bad effects from the huge RF signal input to the preamp.

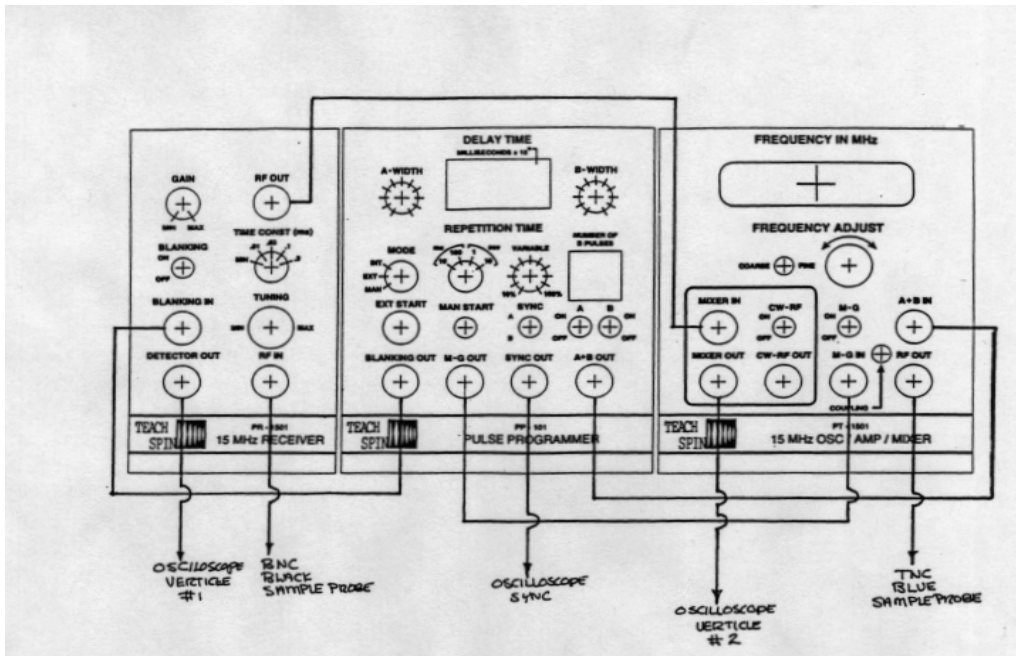

Figure 2. The front panel of the electronics modules and the connections used for these measurements.

Finding the Signal

Place a sample in the probe: H_2O with $CuSO_4$ is a good choice because T_1 , the time constant for recovery of the equilibrium nuclear magnetization, is shortened to a few milliseconds by the paramagnetic Cu^{+} ions. In pure H_2O , $T_1 \sim 2.3$ seconds requiring a time between measurements to be several times this.

Hook up the outputs of both the MIXER (OUT) and RF DETECTOR OUT to the oscilloscope. The following set of values is a good starting point:

Frequency 15.32 MHz
 CWR FON
 A ON, B OFF
 Internal Triggering
 REPETITION 0.1 sec
 SYNC A
 BLANKING ON
 TIME CONST 0.01 ms
 Oscilloscope: 1 Volt/cm and 2 ms/cm scales
 Don't worry about the external start.

Observe the signals. You will generally find the DETECTOR output more useful,

except when it is desirable to measure the beat frequency directly. To understand this, vary the reference frequency and watch the beat frequency change.

Vary the pulse duration τ . Find values of τ for $\pi/2$, π and $3\pi/2$. For example, as the pulse width is increased from the minimum value, the first maximum of signal amplitude (observed with either the detector or mixer signal) corresponds to a $\pi/2$ pulse, and the subsequent minimum to a π pulse. Vary the RF frequency and find ω_0 .

With τ set for a $\pi/2$ pulse, vary the RF frequency and observe the mixer and detector outputs.

You should also use these signals to familiarize yourself with the preamplifier (15 MHz Receiver). The preamp is frequency tunable for maximum matching to the signal frequency. An output for the amplified signal from the pick-up coil is provided, and the preamp gain is variable. Blanking can be turned on and off.

T_2^*

The observed “ring down time” is T_2^* . From NMR theory we have that:

$$\frac{1}{T_2^*} = \frac{1}{2T_1} + \frac{1}{T_2} + \frac{1}{T_2^B} \quad .$$

Use the storage function of the oscilloscope to acquire a single pulse and measure T_2^* . You can also download the scope’s memory to a PC for off line analysis.

The effects of magnetic field inhomogeneity of T_2^* can be investigated by changing the sample position with respect to the permanent magnet pole tips and by changing the pole tip spacing. Both of these adjustments can be made with knobs on the magnet support.

Spin Echo

Spin echo is one of the elegant and most useful features of pulsed NMR and clearly shows that T_2^* has several contributions, in particular due to magnetic field inhomogeneity. Consider a sample in which the atoms are fixed so that each atom is in a slightly different magnetic field. The NMR signal will be made up of the spread of frequencies resulting from the spread in magnetic field at the position of each atom. The frequency spectrum is therefore broadened, and, since each atom has a different frequency, it is called inhomogeneous broadening.

Consider two spins, spatially separated, that have frequencies ω_1 and ω_2 , with $\omega_1 > \omega_2$. After a $\pi/2$ pulse, the two spins are parallel, pointing along the \hat{y}_R axis in the rotating frame. This produces the maximum NMR signal amplitude. After some time, δt , the two spins are out of phase by $\delta\phi = (\omega_1 - \omega_2)\delta t$ radians. The NMR signal is reduced by $\cos(\delta\phi/2)$. Now apply a π pulse. In the rotating frame, the π pulse is a Rabi rotation of π radians of both spins about the

\hat{x}_R axis so that the phase difference is reversed: $\delta\phi' = -\delta\phi$. After another interval δt , the total phase difference is $\delta\phi' + \delta\phi = 0$. The spins are back in phase, and the signal is again a maximum.

Observing this effect shows that name spin echo is quite appropriate. You will use both pulse A and pulse B for this measurement. Set up with triggering (SYNC) from pulse A. Adjust the width of pulse A for $\pi/2$. Now switch to pulse B (pulse A off, SYNC from pulse B, N=1). Set the width of pulse B for π . Now switch both A and B on with SYNC from A and vary the repetition time. You should see the spin echo. Measure the dependence of the echo size on repetition time.

T₂

The ring down time T_2^* is the combination of several contributions, most notable saturation recovery (measured by T_1), dephasing in the presence of fluctuating magnetic fields due to the motions of spins in the lattice (T_2), and inhomogeneous magnetic field broadening (T_2^B). We have seen that the dephasing of spins that leads to inhomogeneous broadening can be reversed using the spin echo sequence. The other contributions to T_2^* are homogeneous, the same for all spins in the sample, and cannot be reversed. Thus, as the echo time is increased, the echo decreases due to the homogeneous broadening effects.

The spin echo sequence could be used with varying echo times to measure the homogenous contributions T_1 and T_2 . Alternatively, a sequence with multiple echos is often employed. To observe this, set up the spin echo experiment, and increase the number of B pulses. Plot the echo amplitudes as a function of B pulse number. The resulting exponential decay has a time constant $\approx T_2$ as long as $T_1 \ll T_2$. You will measure T_1 in the next section.

T₁

Two common methods for measuring T_1 are 1) saturation-recovery and 2) inversion-recovery. Both methods rely on the fact that the spin system is initially perturbed so that the populations are not in equilibrium. The sample is then examined at time intervals following the removal of the perturbation.

In the saturation recovery method the perturbation arises from saturation, so that the populations of the spin states are equalized. In the inversion recovery sequence, the populations are inverted by a π pulse.

To measure T_1 using saturation recovery apply a $\pi/2$ pulse to the nuclear magnetization, M_0 immediately after the pulse is small, nearly 0, and it recovers to thermal equilibrium with the time constant T_1 . Since the NMR signal size just after the pulse is a measure of M_0 before the pulse, you can observe the recovery to thermal equilibrium with a second $\pi/2$ pulse as you vary the time separating the two pulses. WARNING: if M_T is appreciable when the second $\pi/2$ pulse is applied, the signal will not be proportional to M_0 , rather it will be some combination that cannot be easily interpreted. Saturation absorption measurements thus depend on the condition $T_2^* \ll T_1$. Fortunately you can affect and tune T_2^* .

To measure T_2 using inversion recovery apply a π pulse to obtain the population inversion and then sample the magnetization with a $\pi/2$ pulse as you vary the time separating the two pulses. The magnetization will start at $-M_0$ right after the first pulse and head toward $+M_0$ with a time constant T_1 . Note that the signal will pass through zero.

Changing Samples

Now that you are adept at measuring the NMR parameters T_1 , T_2 , etc., you can change samples. Some interesting examples are mineral oil and pure H_2O . What can you learn about these samples?

Other pulse sequences

You can generate other pulse sequences including the MG sequence, which involves a change of phase of the applied RF. See the reading, in particular Slichter's book.

Caveats

It's possible to damage RF electronics, and the pulsed NMR unit is provided with some protection.

DO NOT OPERATE THE RF SOURCE IF THE TNC CABLE IS NOT ATTACHED TO THE B_1 COIL.

DO NOT OPERATE WITH PULSE DUTY FACTOR (PULSE DURATION/REPITION TIME) GREATER THAN 1%.

If overheating occurs, the unit should shut down. This can be reset after the problem is eliminated and the AC power cycled (turned OFF and then ON again).

Permanent magnets are temperature sensitive. The approximate temperature coefficient for this magnet is:

$$\frac{dH}{dT} \approx \frac{4G}{^{\circ}C}.$$