

MC10E195, MC100E195

5V ECL Programmable Delay Chip

The MC10E/100E195 is a programmable delay chip (PDC) designed primarily for clock de-skewing and timing adjustment. It provides variable delay of a differential ECL input transition.

The delay section consists of a chain of gates organized as shown in the logic symbol. The first two delay elements feature gates that have been modified to have delays 1.25 and 1.5 times the basic gate delay of approximately 80 ps. These two elements provide the E195 with a digitally-selectable resolution of approximately 20 ps. The required device delay is selected by the seven address inputs D[0:6], which are latched on chip by a high signal on the latch enable (LEN) control.

Because the delay programmability of the E195 is achieved by purely differential ECL gate delays the device will operate at frequencies of > 1.0 GHz while maintaining over 600 mV of output swing.

The E195 thus offers very fine resolution, at very high frequencies, that is selectable entirely from a digital input allowing for very accurate system clock timing.

An eighth latched input, D7, is provided for cascading multiple PDC's for increased programmable range. The cascade logic allows full control of multiple PDC's, at the expense of only a single added line to the data bus for each additional PDC, without the need for any external gating.

The V_{BB} pin, an internally generated voltage supply, is available to this device only. For single-ended input conditions, the unused differential input is connected to V_{BB} as a switching reference voltage. V_{BB} may also rebias AC coupled inputs. When used, decouple V_{BB} and V_{CC} via a 0.01 μ F capacitor and limit current sourcing or sinking to 0.5 mA. When not used, V_{BB} should be left open.

The 100 Series contains temperature compensation.

- 2.0 ns Worst Case Delay Range
- ≈ 20 ps/Delay Step Resolution
- >1.0 GHz Bandwidth
- On Chip Cascade Circuitry
- PECL Mode Operating Range: $V_{CC} = 4.2$ V to 5.7 V with $V_{EE} = 0$ V
- NECL Mode Operating Range: $V_{CC} = 0$ V with $V_{EE} = -4.2$ V to -5.7 V
- Internal Input 50 k Ω Pulldown Resistors
- ESD Protection: Human Body Model; > 2 kV, Machine Model; > 200 V
- Meets or Exceeds JEDEC Spec EIA/JESD78 IC Latchup Test
- Moisture Sensitivity Level 1
For Additional Information, see Application Note AND8003/D
- Flammability Rating: UL 94 V-0 @ 0.125 in, Oxygen Index: 28 to 34
- Transistor Count = 368 devices



ON Semiconductor®

<http://onsemi.com>

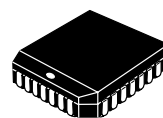

PLCC-28
FN SUFFIX
CASE 776

MARKING DIAGRAMS

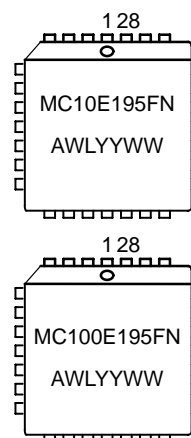

A = Assembly Location
WL = Wafer Lot
YY = Year
WW = Work Week

ORDERING INFORMATION

See detailed ordering and shipping information in the package dimensions section on page 9 of this data sheet.

MC10E195, MC100E195

LOGIC DIAGRAM AND PINOUT ASSIGNMENT

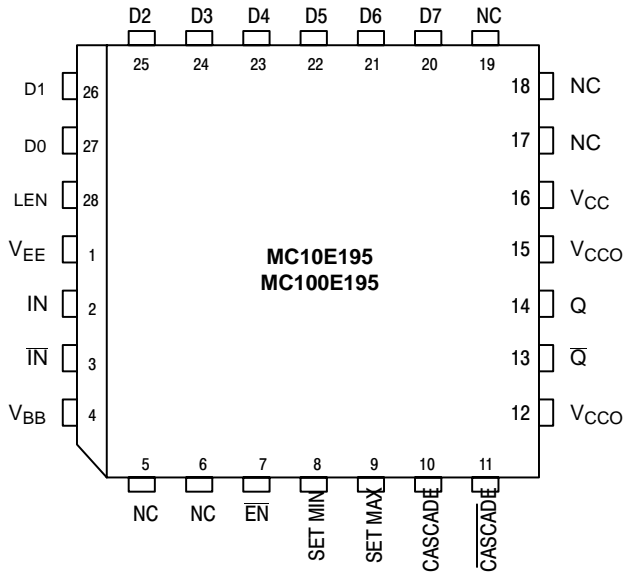

Figure 1. Pinout:28-Lead PLCC (Top View)

*All V_{CC} and V_{CCO} pins are tied together on the die.

Warning: All V_{CC}, V_{CCO}, and V_{EE} pins must be externally connected to Power Supply to guarantee proper operation.

Table 1. PIN DESCRIPTION

PIN	FUNCTION
IN/ \overline{IN}	ECL Signal Input
EN	ECL Input Enable
D[0:7]	ECL MUX Select Inputs
Q/ \overline{Q}	ECL Signal Output
LEN	ECL Latch Enable
SET MIN	ECL Min Delay Set
SET MAX	ECL Max Delay Set
CASCADE, $\overline{CASCADE}$	ECL Cascade Signal
V _{BB}	Reference Voltage Output
V _{CC} , V _{CCO}	Positive Supply
V _{EE}	Negative Supply
NC	No Connect

Table 2. TRUTH TABLE

EN	LEN	Q = IN
L	L	Q = IN
H	H	Q Logic Low
L	L	Pass Through D[0:10]
L	H	Latch D[0:10]
L	L	Normal Mode
L	H	Min Delay Path
L	L	Normal Mode
L	H	Max Delay Path

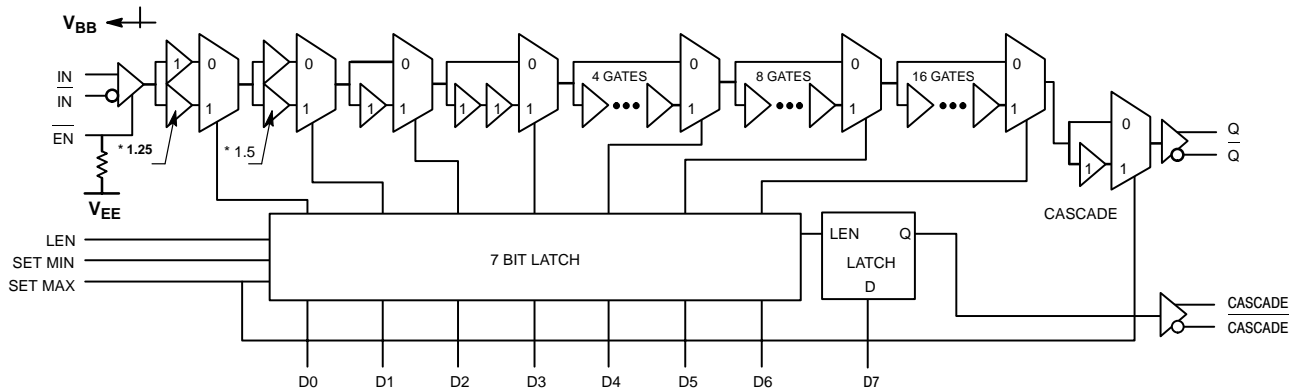

* delays are 25% or 50% longer than standard (standard \approx 80 ps)

Figure 2. Logic Diagram – Simplified

MC10E195, MC100E195

Table 3. MAXIMUM RATINGS

Symbol	Parameter	Condition 1	Condition 2	Rating	Unit
V_{CC}	PECL Mode Power Supply	$V_{EE} = 0\text{ V}$		8	V
V_{EE}	NECL Mode Power Supply	$V_{CC} = 0\text{ V}$		-8	V
V_I	PECL Mode Input Voltage	$V_{EE} = 0\text{ V}$	$V_I \leq V_{CC}$	6	V
	NECL Mode Input Voltage	$V_{CC} = 0\text{ V}$	$V_I \geq V_{EE}$	-6	V
I_{out}	Output Current	Continuous Surge		50	mA
				100	mA
I_{BB}	V_{BB} Sink/Source			± 0.5	mA
T_A	Operating Temperature Range			0 to +85	$^{\circ}\text{C}$
T_{stg}	Storage Temperature Range			-65 to +150	$^{\circ}\text{C}$
θ_{JA}	Thermal Resistance (Junction-to-Ambient)	0 lfpm	PLCC-28	63.5	$^{\circ}\text{C}/\text{W}$
		500 lfpm	PLCC-28	43.5	$^{\circ}\text{C}/\text{W}$
θ_{JC}	Thermal Resistance (Junction-to-Case)	Standard Board	PLCC-28	22 to 26	$^{\circ}\text{C}/\text{W}$
V_{EE}	PECL Operating Range			4.2 to 5.7	V
	NECL Operating Range			-5.7 to -4.2	V
T_{sol}	Wave Solder	< 2 to 3 sec @ 248 $^{\circ}\text{C}$		265	$^{\circ}\text{C}$

Maximum ratings are those values beyond which device damage can occur. Maximum ratings applied to the device are individual stress limit values (not normal operating conditions) and are not valid simultaneously. If these limits are exceeded, device functional operation is not implied, damage may occur and reliability may be affected.

MC10E195, MC100E195

Table 4. 10E SERIES PECL DC CHARACTERISTICS $V_{CCx}= 5.0\text{ V}$; $V_{EE}= 0.0\text{ V}$ (Note 1)

Symbol	Characteristic	0°C			25°C			85°C			Unit
		Min	Typ	Max	Min	Typ	Max	Min	Typ	Max	
I_{EE}	Power Supply Current		130	156		130	156		130	156	mA
V_{OH}	Output HIGH Voltage (Note 2)	3980	4070	4160	4020	4105	4190	4090	4185	4280	mV
V_{OL}	Output LOW Voltage (Note 2)	3050	3210	3370	3050	3210	3370	3050	3227	3405	mV
V_{IH}	Input HIGH Voltage (Single-Ended)	3830	3995	4160	3870	4030	4190	3940	4110	4280	mV
V_{IL}	Input LOW Voltage (Single-Ended)	3050	3285	3520	3050	3285	3520	3050	3302	3555	mV
V_{BB}	Output Voltage Reference	3.62		3.74	3.65		3.75	3.69		3.81	V
V_{IHCMR}	Input HIGH Voltage Common Mode Range (Differential Configuration) (Note 3)	2.2		4.6	2.2		4.6	2.2		4.6	V
I_{IH}	Input HIGH Current			150			150			150	μA
I_{IL}	Input LOW Current	0.5	0.3		0.5	0.25		0.3	0.2		μA

NOTE: Device will meet the specifications after thermal equilibrium has been established when mounted in a test socket or printed circuit board with maintained transverse airflow greater than 500 lfm. Electrical parameters are guaranteed only over the declared operating temperature range. Functional operation of the device exceeding these conditions is not implied. Device specification limit values are applied individually under normal operating conditions and not valid simultaneously.

1. Input and output parameters vary 1:1 with V_{CC} . V_{EE} can vary $-0.46\text{ V} / +0.06\text{ V}$.
2. Outputs are terminated through a $50\ \Omega$ resistor to $V_{CC} - 2.0\text{ V}$.
3. V_{IHCMR} min varies 1:1 with V_{EE} , max varies 1:1 with V_{CC} .

Table 5. 10E SERIES NECL DC CHARACTERISTICS $V_{CCx}= 0.0\text{ V}$; $V_{EE}= -5.0\text{ V}$ (Note 4)

Symbol	Characteristic	0°C			25°C			85°C			Unit
		Min	Typ	Max	Min	Typ	Max	Min	Typ	Max	
I_{EE}	Power Supply Current		130	156		130	156		130	156	mA
V_{OH}	Output HIGH Voltage (Note 5)	-1020	-930	-840	-980	-895	-810	-910	-815	-720	mV
V_{OL}	Output LOW Voltage (Note 5)	-1950	-1790	-1630	-1950	-1790	-1630	-1950	-1773	-1595	mV
V_{IH}	Input HIGH Voltage (Single-Ended)	-1170	-1005	-840	-1130	-970	-810	-1060	-890	-720	mV
V_{IL}	Input LOW Voltage (Single-Ended)	-1950	-1715	-1480	-1950	-1715	-1480	-1950	-1698	-1445	mV
V_{BB}	Output Voltage Reference	-1.38		-1.27	-1.35		-1.25	-1.31		-1.19	V
V_{IHCMR}	Input HIGH Voltage Common Mode Range (Differential Configuration) (Note 6)	-2.8		-0.4	-2.8		-0.4	-2.8		-0.4	V
I_{IH}	Input HIGH Current			150			150			150	μA
I_{IL}	Input LOW Current	0.5	0.3		0.5	0.065		0.3	0.2		μA

NOTE: Device will meet the specifications after thermal equilibrium has been established when mounted in a test socket or printed circuit board with maintained transverse airflow greater than 500 lfm. Electrical parameters are guaranteed only over the declared operating temperature range. Functional operation of the device exceeding these conditions is not implied. Device specification limit values are applied individually under normal operating conditions and not valid simultaneously.

4. Input and output parameters vary 1:1 with V_{CC} . V_{EE} can vary $-0.46\text{ V} / +0.06\text{ V}$.
5. Outputs are terminated through a $50\ \Omega$ resistor to $V_{CC} - 2.0\text{ V}$.
6. V_{IHCMR} min varies 1:1 with V_{EE} , max varies 1:1 with V_{CC} .

MC10E195, MC100E195

Table 6. 100E SERIES PECL DC CHARACTERISTICS $V_{CCx}= 5.0\text{ V}$; $V_{EE}= 0.0\text{ V}$ (Note 7)

Symbol	Characteristic	0°C			25°C			85°C			Unit
		Min	Typ	Max	Min	Typ	Max	Min	Typ	Max	
I_{EE}	Power Supply Current		130	156		130	156		150	179	mA
V_{OH}	Output HIGH Voltage (Note 8)	3975	4050	4120	3975	4050	4120	3975	4050	4120	mV
V_{OL}	Output LOW Voltage (Note 8)	3190	3295	3380	3190	3255	3380	3190	3260	3380	mV
V_{IH}	Input HIGH Voltage (Single-Ended)	3835	3975	4120	3835	3975	4120	3835	3975	4120	mV
V_{IL}	Input LOW Voltage (Single-Ended)	3190	3355	3525	3190	3355	3525	3190	3355	3525	mV
V_{BB}	Output Voltage Reference	3.62		3.74	3.62		3.74	3.62		3.74	V
V_{IHCMR}	Input HIGH Voltage Common Mode Range (Differential Configuration) (Note 9)	2.2		4.6	2.2		4.6	2.2		4.6	V
I_{IH}	Input HIGH Current			150			150			150	μA
I_{IL}	Input LOW Current	0.5	0.3		0.5	0.25		0.5	0.2		μA

NOTE: Device will meet the specifications after thermal equilibrium has been established when mounted in a test socket or printed circuit board with maintained transverse airflow greater than 500 lfm. Electrical parameters are guaranteed only over the declared operating temperature range. Functional operation of the device exceeding these conditions is not implied. Device specification limit values are applied individually under normal operating conditions and not valid simultaneously.

7. Input and output parameters vary 1:1 with V_{CC} . V_{EE} can vary $-0.46\text{ V} / +0.8\text{ V}$.

8. Outputs are terminated through a $50\ \Omega$ resistor to $V_{CC} - 2.0\text{ V}$.

9. V_{IHCMR} min varies 1:1 with V_{EE} , max varies 1:1 with V_{CC} .

Table 7. 100E SERIES NECL DC CHARACTERISTICS $V_{CCx}= 0.0\text{ V}$; $V_{EE}= -5.0\text{ V}$ (Note 10)

Symbol	Characteristic	0°C			25°C			85°C			Unit
		Min	Typ	Max	Min	Typ	Max	Min	Typ	Max	
I_{EE}	Power Supply Current		130	156		130	156		150	179	mA
V_{OH}	Output HIGH Voltage (Note 11)	-1025	-950	-880	-1025	-950	-880	-1025	-950	-880	mV
V_{OL}	Output LOW Voltage (Note 11)	-1810	-1705	-1620	-1810	-1745	-1620	-1810	-1740	-1620	mV
V_{IH}	Input HIGH Voltage (Single-Ended)	-1165	-1025	-880	-1165	-1025	-880	-1165	-1025	-880	mV
V_{IL}	Input LOW Voltage (Single-Ended)	-1810	-1645	-1475	-1810	-1645	-1475	-1810	-1645	-1475	mV
V_{BB}	Output Voltage Reference	-1.38		-1.26	-1.38		-1.26	-1.38		-1.26	V
V_{IHCMR}	Input HIGH Voltage Common Mode Range (Differential Configuration) (Note 12)	-2.8		-0.4	-2.8		-0.4	-2.8		-0.4	V
I_{IH}	Input HIGH Current			150			150			150	μA
I_{IL}	Input LOW Current	0.5	0.3		0.5	0.25		0.5	0.2		μA

NOTE: Device will meet the specifications after thermal equilibrium has been established when mounted in a test socket or printed circuit board with maintained transverse airflow greater than 500 lfm. Electrical parameters are guaranteed only over the declared operating temperature range. Functional operation of the device exceeding these conditions is not implied. Device specification limit values are applied individually under normal operating conditions and not valid simultaneously.

10. Input and output parameters vary 1:1 with V_{CC} . V_{EE} can vary $-0.46\text{ V} / +0.8\text{ V}$.

11. Outputs are terminated through a $50\ \Omega$ resistor to $V_{CC} - 2.0\text{ V}$.

12. V_{IHCMR} min varies 1:1 with V_{EE} , max varies 1:1 with V_{CC} .

MC10E195, MC100E195

Table 8. AC CHARACTERISTICS $V_{CCx}= 5.0\text{ V}; V_{EE}= 0.0\text{ V}$ or $V_{CCx}= 0.0\text{ V}; V_{EE}= -5.0\text{ V}$ (Note 13)

Symbol	Characteristic	0°C			25°C			85°C			Unit
		Min	Typ	Max	Min	Typ	Max	Min	Typ	Max	
f _{MAX}	Maximum Toggle Frequency					> 1.0					GHz
t _{PLH} t _{PHL}	Propagation Delay IN to Q; Tap = 0 IN to Q; Tap = 127 $\overline{\text{EN}}$ to Q; Tap = 0 D7 to CASCADE	1210 3200 1250 300	1360 3570 1450 450	1510 3970 1650 700	1240 3270 1275 300	1390 3630 1475 450	1540 4030 1675 700	1440 3885 1350 300	1590 4270 1650 450	1765 4710 1950 700	ps
t _{RANGE}	Programmable Range t _{PD} (max) – t _{PD} (min)	2000	2175		2050	2240		2375	2580		ps
Δt	Step Delay (Note 19) D0 High D1 High D2 High D3 High D4 High D5 High D6 High		17 34 68 115 272 544 1088			17.5 35 70 140 280 560 1120			21 42 84 168 336 672 1344	120 205 380 740 1450	ps
L _{in}	Linearity (Note 20)	D1	D0		D1	D0		D1	D0		
t _{SKEW}	Duty Cycle Skew t _{PHL} – t _{PLH} (Note 14)		±30			±30			±30		ps
t _{JITTER}	Random Clock Jitter (RMS)		< 5			< 5			< 5		ps
t _s	Setup Time D to LEN D to IN (Note 15) $\overline{\text{EN}}$ to IN (Note 16)	200 800 200	0		200 800 200	0		200 800 200	0		ps
t _h	Hold Time LEN to D IN to $\overline{\text{EN}}$ (Note 17)	500 0	250		500 0	250		500 0	250		ps
t _R	Release Time $\overline{\text{EN}}$ to IN (Note 18) SET MAX to LEN SET MIN to LEN	300 800 800			300 800 800			300 800 800			ps
t _{jit}	Jitter		< 5			< 5			< 5		ps
t _r t _f	Output Rise/Fall Time 20–80% (Q) 20–80% (CASCADE)	125 300	225 450	325 650	125 300	225 450	325 650	125 300	225 450	325 650	ps

NOTE: Device will meet the specifications after thermal equilibrium has been established when mounted in a test socket or printed circuit board with maintained transverse airflow greater than 500 lpm. Electrical parameters are guaranteed only over the declared operating temperature range. Functional operation of the device exceeding these conditions is not implied. Device specification limit values are applied individually under normal operating conditions and not valid simultaneously.

13. 10 Series: V_{EE} can vary $-0.46\text{ V} / +0.06\text{ V}$.
100 Series: V_{EE} can vary $-0.46\text{ V} / +0.8\text{ V}$.

14. Duty cycle skew guaranteed only for differential operation measured from the cross point of the input to the cross point of the output.

15. This setup time defines the amount of time prior to the input signal the delay tap of the device must be set.

16. This setup time is the minimum time that $\overline{\text{EN}}$ must be asserted prior to the next transition of IN/ $\overline{\text{IN}}$ to prevent an output response greater than $\pm 75\text{ mV}$ to that IN/ $\overline{\text{IN}}$ transition.

17. This hold time is the minimum time that $\overline{\text{EN}}$ must remain asserted after a negative going IN or positive going $\overline{\text{IN}}$ to prevent an output response greater than $\pm 75\text{ mV}$ to that IN/ $\overline{\text{IN}}$ transition.

18. This release time is the minimum time that $\overline{\text{EN}}$ must be deasserted prior to the next IN/ $\overline{\text{IN}}$ transition to ensure an output response that meets the specified IN to Q propagation delay and transition times.

19. Specification limits represent the amount of delay added with the assertion of each individual delay control pin. The various combinations of asserted delay control inputs will typically realize D0 resolution steps across the specified programmable range.

20. The linearity specification guarantees to which delay control input the programmable steps will be monotonic (i.e. increasing delay steps for increasing binary counts on the control inputs Dn). Typically the device will be monotonic to the D0 input, however under worst case conditions and process variation, delays could decrease slightly with increasing binary counts when the D0 input is the LSB. With the D1 input as the Least Significant Bit (LSB), the device is guaranteed to be monotonic over all specified environmental conditions and process variation.

MC10E195, MC100E195

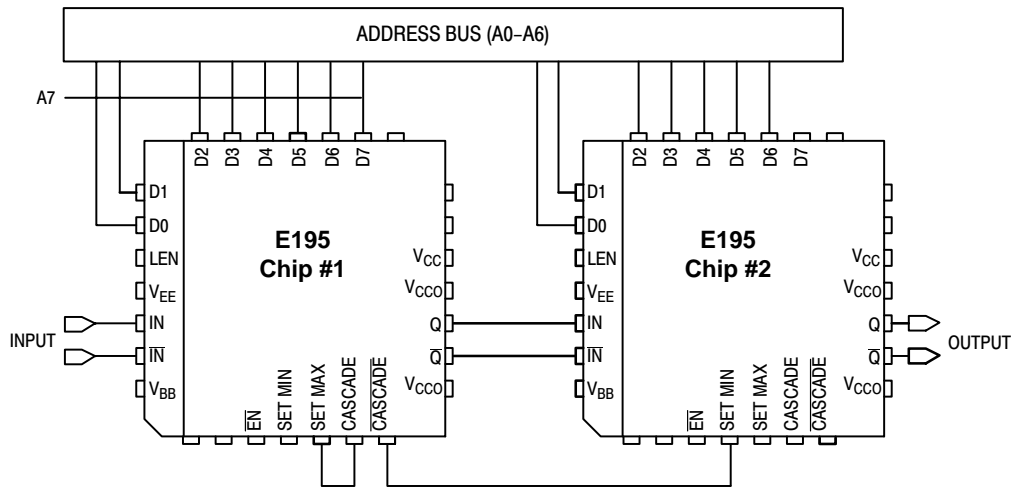

Figure 3. Cascading Interconnect Architecture

Cascading Multiple E195's

To increase the programmable range of the E195 internal cascade circuitry has been included. This circuitry allows for the cascading of multiple E195's without the need for any external gating. Furthermore this capability requires only one more address line per added E195. Obviously cascading multiple PDC's will result in a larger programmable range however this increase is at the expense of a longer minimum delay.

Figure 3 illustrates the interconnect scheme for cascading two E195's. As can be seen, this scheme can easily be expanded for larger E195 chains. The D7 input of the E195 is the cascade control pin. With the interconnect scheme of Figure 3 when D7 is asserted it signals the need for a larger programmable range than is achievable with a single device.

An expansion of the latch section of the block diagram is pictured below. Use of this diagram will simplify the explanation of how the cascade circuitry works. When D7 of chip #1 above is low the cascade output will also be low while the cascade bar output will be a logical high. In this condition the SET MIN pin of chip #2 will be asserted and thus all of the latches of chip #2 will be reset and the device will be set at its minimum delay. Since the RESET and SET inputs of the latches are overriding any changes on the A0-A6 address bus will not affect the operation of chip #2.

Chip #1 on the other hand will have both SET MIN and SET MAX de-asserted so that its delay will be controlled entirely by the address bus A0-A6. If the delay needed is greater than can be achieved with 31.75 gate delays (111111 on the A0-A6 address bus) D7 will be asserted to signal the need to cascade the delay to the next E195 device. When D7 is asserted the SET MIN pin of chip #2 will be de-asserted and the delay will be controlled by the A0-A6 address bus. Chip #1 on the other hand will have its SET MAX pin asserted resulting in the device delay to be independent of the A0-A6 address bus.

When the SET MAX pin of chip #1 is asserted the D0 and D1 latches will be reset while the rest of the latches will be set. In addition, to maintain monotonicity an additional gate delay is selected in the cascade circuitry. As a result when D7 of chip #1 is asserted the delay increases from 31.75 gates to 32 gates. A 32 gate delay is the maximum delay setting for the E195.

To expand this cascading scheme to more devices one simply needs to connect the D7 input and CASCADE outputs of the current most significant E195 to the new most significant E195 in the same manner as pictured in Figure 3. The only addition to the logic is the increase of one line to the address bus for cascade control of the second PDC.

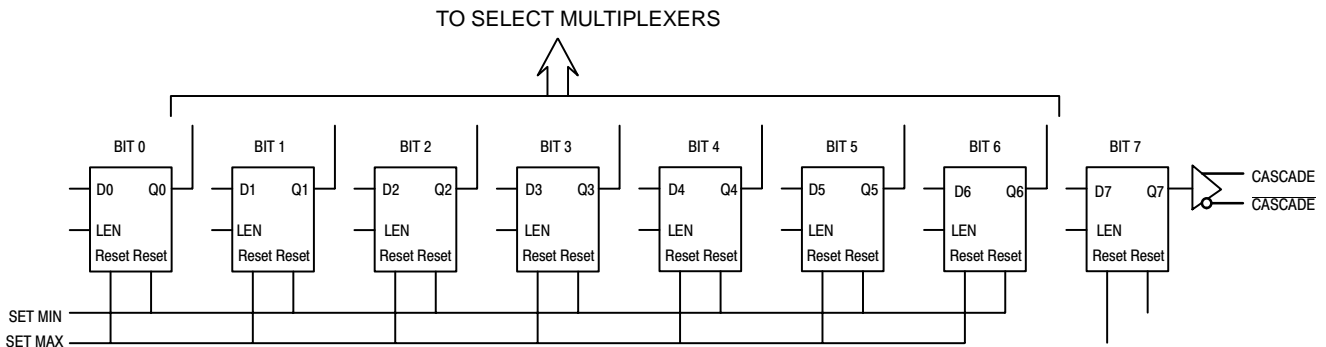

Figure 4. Expansion of the Latch Section of the E195 Block Diagram

MC10E195, MC100E195

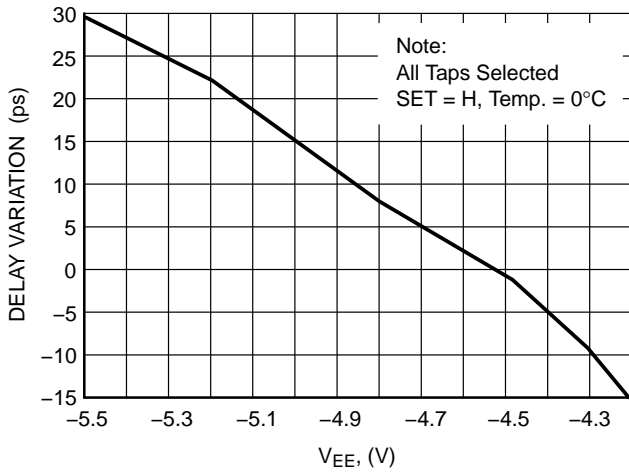

Figure 5. Change in Delay vs. Change in Supply Voltage

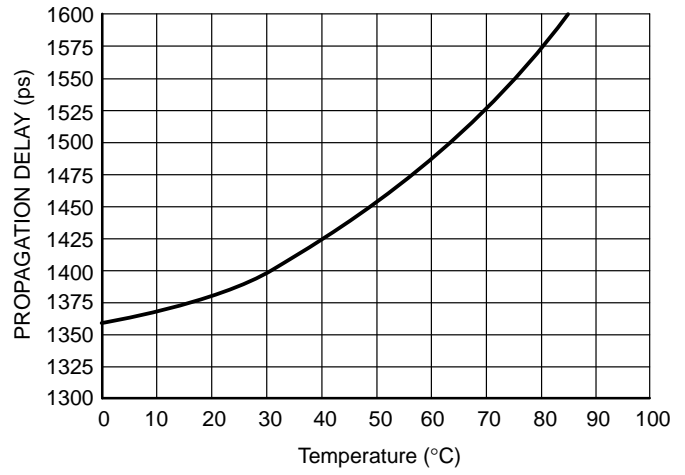

Figure 6. Delay vs. Temperature (Fixed Path)

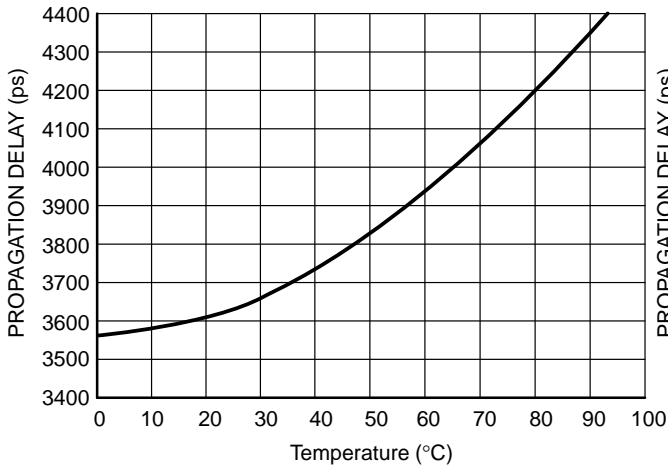

Figure 7. Delay vs. Temperature (Max. Delay).

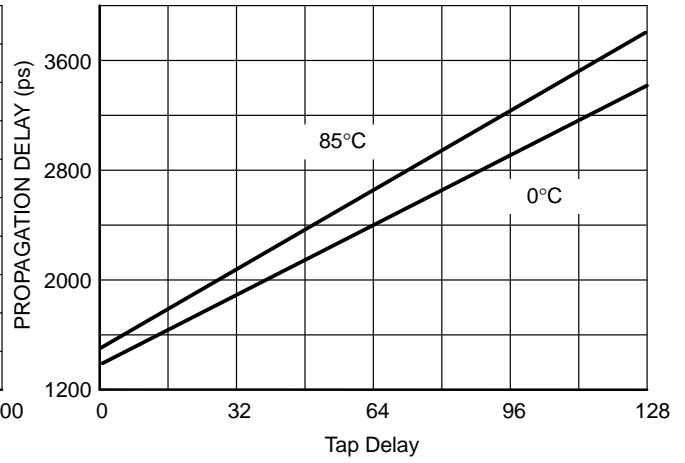

Figure 8. 100E195 Temperature Effects on Delay.

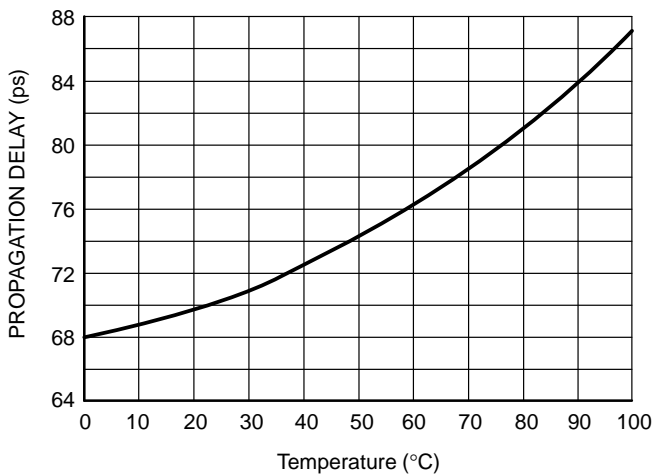

Figure 9. Delay vs. Temperature (Per Gate).

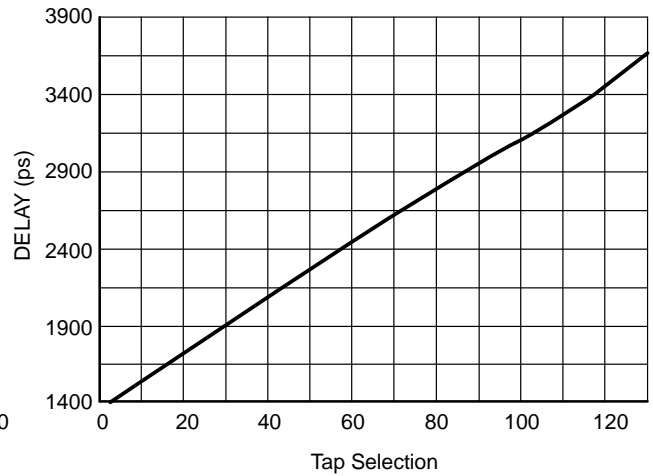
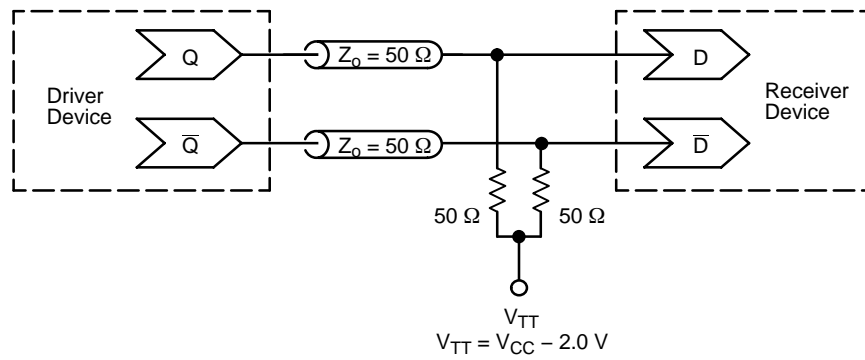

Figure 10. E195 Delay Linearity.

MC10E195, MC100E195



**Figure 11. Typical Termination for Output Driver and Device Evaluation
(See Application Note AND8020/D – Termination of ECL Logic Devices.)**

ORDERING INFORMATION

Device	Package	Shipping†
MC10E195FN	PLCC-28	37 Units / Rail
MC10E195FNR2	PLCC-28	500 / Tape & Reel
MC100E195FN	PLCC-28	37 Units / Rail
MC100E195FNR2	PLCC-28	500 / Tape & Reel

†For information on tape and reel specifications, including part orientation and tape sizes, please refer to our Tape and Reel Packaging Specifications Brochure, BRD8011/D.

MC10E195, MC100E195

Resource Reference of Application Notes

- AN1405/D** – ECL Clock Distribution Techniques
- AN1406/D** – Designing with PECL (ECL at +5.0 V)
- AN1503/D** – ECLinPS™ I/O SPiCE Modeling Kit
- AN1504/D** – Metastability and the ECLinPS Family
- AN1568/D** – Interfacing Between LVDS and ECL
- AN1642/D** – The ECL Translator Guide
- AND8001/D** – Odd Number Counters Design
- AND8002/D** – Marking and Date Codes
- AND8020/D** – Termination of ECL Logic Devices
- AND8066/D** – Interfacing with ECLinPS
- AND8090/D** – AC Characteristics of ECL Devices

MC10E195, MC100E195

PACKAGE DIMENSIONS

PLCC-28
FN SUFFIX
PLASTIC PLCC PACKAGE
CASE 776-02
ISSUE E

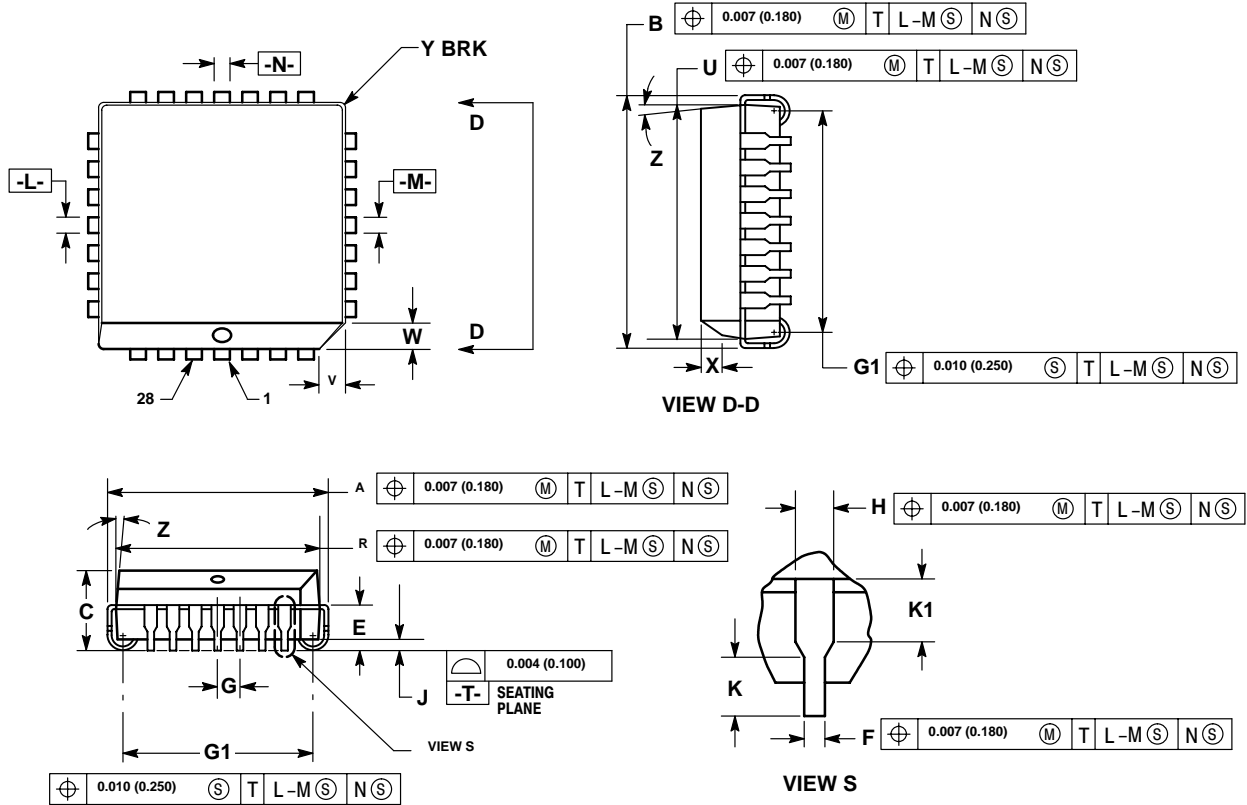

NOTES:

- DATUMS -L-, -M-, AND -N- DETERMINED WHERE TOP OF LEAD SHOULDER EXITS PLASTIC BODY AT MOLD PARTING LINE.
- DIM G1, TRUE POSITION TO BE MEASURED AT DATUM -T-, SEATING PLANE.
- DIM R AND U DO NOT INCLUDE MOLD FLASH. ALLOWABLE MOLD FLASH IS 0.010 (0.250) PER SIDE.
- DIMENSIONING AND TOLERANCING PER ANSI Y14.5M, 1982.
- CONTROLLING DIMENSION: INCH.
- THE PACKAGE TOP MAY BE SMALLER THAN THE PACKAGE BOTTOM BY UP TO 0.012 (0.300). DIMENSIONS R AND U ARE DETERMINED AT THE OUTERMOST EXTREMES OF THE PLASTIC BODY EXCLUSIVE OF MOLD FLASH, TIE BAR BURRS, GATE BURRS AND INTERLEAD FLASH, BUT INCLUDING ANY MISMATCH BETWEEN THE TOP AND BOTTOM OF THE PLASTIC BODY.
- DIMENSION H DOES NOT INCLUDE DAMBAR PROTRUSION OR INTRUSION. THE DAMBAR PROTRUSION(S) SHALL NOT CAUSE THE H DIMENSION TO BE GREATER THAN 0.037 (0.940). THE DAMBAR INTRUSION(S) SHALL NOT CAUSE THE H DIMENSION TO BE SMALLER THAN 0.025 (0.635).

DIM	INCHES		MILLIMETERS	
	MIN	MAX	MIN	MAX
A	0.485	0.495	12.32	12.57
B	0.485	0.495	12.32	12.57
C	0.165	0.180	4.20	4.57
E	0.090	0.110	2.29	2.79
F	0.013	0.019	0.33	0.48
G	0.050 BSC		1.27 BSC	
H	0.026	0.032	0.66	0.81
J	0.020	—	0.51	—
K	0.025	—	0.64	—
R	0.450	0.456	11.43	11.58
U	0.450	0.456	11.43	11.58
V	0.042	0.048	1.07	1.21
W	0.042	0.048	1.07	1.21
X	0.042	0.056	1.07	1.42
Y	—	0.020	—	0.50
Z	2°	10°	2°	10°
G1	0.410	0.430	10.42	10.92
K1	0.040	—	1.02	—

MC10E195, MC100E195

ECLinPS is a trademark of Semiconductor Components Industries, LLC (SCILLC).

ON Semiconductor and  are registered trademarks of Semiconductor Components Industries, LLC (SCILLC). SCILLC reserves the right to make changes without further notice to any products herein. SCILLC makes no warranty, representation or guarantee regarding the suitability of its products for any particular purpose, nor does SCILLC assume any liability arising out of the application or use of any product or circuit, and specifically disclaims any and all liability, including without limitation special, consequential or incidental damages. "Typical" parameters which may be provided in SCILLC data sheets and/or specifications can and do vary in different applications and actual performance may vary over time. All operating parameters, including "Typicals" must be validated for each customer application by customer's technical experts. SCILLC does not convey any license under its patent rights nor the rights of others. SCILLC products are not designed, intended, or authorized for use as components in systems intended for surgical implant into the body, or other applications intended to support or sustain life, or for any other application in which the failure of the SCILLC product could create a situation where personal injury or death may occur. Should Buyer purchase or use SCILLC products for any such unintended or unauthorized application, Buyer shall indemnify and hold SCILLC and its officers, employees, subsidiaries, affiliates, and distributors harmless against all claims, costs, damages, and expenses, and reasonable attorney fees arising out of, directly or indirectly, any claim of personal injury or death associated with such unintended or unauthorized use, even if such claim alleges that SCILLC was negligent regarding the design or manufacture of the part. SCILLC is an Equal Opportunity/Affirmative Action Employer. This literature is subject to all applicable copyright laws and is not for resale in any manner.

PUBLICATION ORDERING INFORMATION

LITERATURE FULFILLMENT:

Literature Distribution Center for ON Semiconductor
P.O. Box 5163, Denver, Colorado 80217 USA

Phone: 303-675-2175 or 800-344-3860 Toll Free USA/Canada

Fax: 303-675-2176 or 800-344-3867 Toll Free USA/Canada

Email: orderlit@onsemi.com

N. American Technical Support: 800-282-9855 Toll Free
USA/Canada

Japan: ON Semiconductor, Japan Customer Focus Center
2-9-1 Kamimeguro, Meguro-ku, Tokyo, Japan 153-0051
Phone: 81-3-5773-3850

ON Semiconductor Website: <http://onsemi.com>

Order Literature: <http://www.onsemi.com/litorder>

For additional information, please contact your
local Sales Representative.